



Flathead 1939-48
"Front Mount"



ALTERNATOR WIRING INSTRUCTIONS

Important Notes: "6V + Ground ONLY"

- These units are internally regulated and the OE external regulator must be bypassed, removed, or used for appearance only
- All units supplied with pulley for 5/8" V belt
(Additional pulleys available)

Charge Indicator "Gen Light" Function
This ONLY Applies To Part Numbers Ending in -2
This connection has no effect on charging performance.
(see additional instructions)

WARNING: DO NOT
use on 1936-39 with
generator mounted
radiator fan!

"Gen Light Post Size 10-24
(-2 Part Numbers Only)

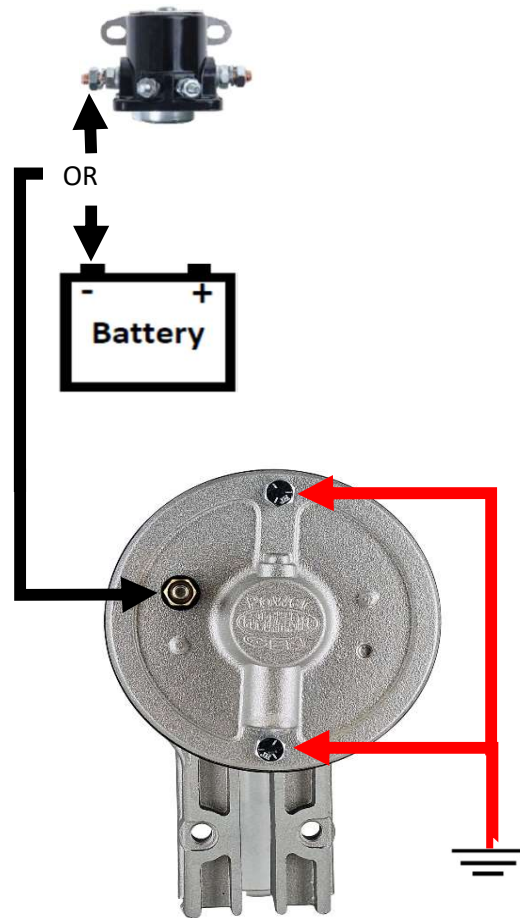

Disconnect Battery Positive (+)

READ ALL INSTRUCTIONS IN BOX!

Charge Wires: use minimum 8 gauge up to 6ft.

Ammeters: Do not reconnect the factory ammeter when using these units. Factory ammeters are typically limited to 30 amps. Please consider a volt gauge to monitor your charging system

Alternator Ground: The OE bracket will not supply a solid alternator ground. Always add an 8 gauge ground lead from alternator housing to engine block

Battery must have a clean ground to the engine block.

Wire Connections: Be sure all terminals are crimped securely, and connections are clean and tight.

Belt Tension: Inspect belt for signs of cracking or glazing. Replace if needed. **A loose belt will cause intermittent charging and generate excessive heat resulting in premature unit/bearing failure. Keep in mind "Alternator tight not generator loose.**

A fully charged battery is at least 6.4V, not 6.0V
A weak/defective battery will cause premature failure.
Never disconnect the battery with engine running! this causes voltage spikes that will damage the alternator

**FAILURE TO FOLLOW THESE INSTRUCTIONS MAY
VOID YOUR WARRANTY**



Powermaster Performance
1833 Downs Dr
West Chicago, IL 60185
www.powermasterperformance.com

PowerGEN Application Guide

Tech/Sales (630) 849-7754

E-mail tech@powermasterperformance.com



	A	B	C	D	E	F
	Description					
	Standard			Part Number		
	Pulley			Chrome	Polish	Black
GM PowerGEN (A)						
90A GM Long (7.1" Fld Hsg) 12V			3/8"	182051	282051	82051
90A GM Long (7.1" Fld Hsg) 12V w/ Lamp Term			3/8"	182051-2	282051-2	82051-2
90A GM Long (7.1" Fld Hsg) 6V Pos Grd			3/8"	182056	282056	82056
90A GM Long (7.1" Fld Hsg) 6V Neg Grd '48-'54			3/8"	182057	282057	82057
GM PowerGEN (B)						
90A GM Short (6" Fld Hsg) 12V			3/8"	182111	282111	82111
90A GM Short (6" Fld Hsg) 12V w/ Lamp Term			3/8"	182111-2	282111-2	82111-2
90A GM Short (6" Fld Hsg) 6V Pos Grd			3/8"	182116	282116	82116
90A GM Short (6" Fld Hsg) 6V Neg Grd '48-'54			3/8"	182117	282117	82117
Ford Flathead PowerGEN (C)						
90A Ford '39-'48, 12V			5/8"	182011	282011	82011
90A Ford '39-'48, 12V w/ Lamp Term			5/8"	182011-2	282011-2	82011-2
90A Ford '39-'48, 12V "Shorty" 1.5" Shorter			5/8"	182013	282013	82013
90A Ford '39-'48, 12V w/ Lamp Term "Shorty" 1.5" Shorter			5/8"	182013-2	282013-2	82013-2
90A Ford '39-'48, 6V Pos Grd			5/8"	182016	282016	82016
Ford Flathead PowerGEN (D)						
90A Ford Strap Mtg. '49-'53, 12V			5/8"	182021	282021	82021
90A Ford Strap Mtg. '49-'53, 12V w/ Lamp Term			5/8"	182021-2	282021-2	82021-2
90A Ford Strap Mtg. '49-'53, 12V "Shorty" 1.5" Shorter			5/8"	182023	282023	82023
90A Ford Strap Mtg. '49-'53, 12V w/ Lamp Term "Shorty" 1.5" Shorter			5/8"	182023-2	282023-2	82023-2
90A Ford Strap Mtg. '49-'53, 6V Pos Grd			5/8"	182026	282026	82026
Ford PowerGEN (E)						
90A Ford Swing Mtg. 12V			3/8"	182101	282101	82101
90A Ford Swing Mtg. 12V w/ Lamp Term			3/8"	182101-2	282101-2	82101-2
90A Ford Swing Mtg. 6V Pos Grd			3/8"	182106	282106	82106
90A Ford T-Bird 1956-57 12V			1/2"	182155	282155	82155
90A Ford T-Bird 1956-57 12V w/ Lamp Term			1/2"	182155-2	282155-2	82155-2
90A Ford T-Bird 1955 6V Pos Grd—use '56-'57 p/n's for 12V upgrade			1/2"	182156	282156	82156
Universal PowerGEN (F)						
90A "Universal" 12V			5/8"	182091	282091	82091
90A "Universal" 12V w/ Lamp Term			5/8"	182091-2	282091-2	82091-2
90A "Universal" 6V Pos Grd			5/8"	182096	282096	82096



CHROME PULLEYS

- 3/8" Belt
P/N 1130
- 1/2" Belt
P/N 1132
- 5/8" Belt
P/N 1134
- 3/4" Belt
P/N 1136

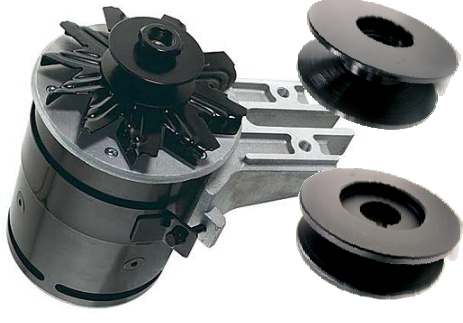

BLACK PULLEYS

- 3/8" Belt
P/N 1131
- 1/2" Belt
P/N 1133
- 5/8" Belt
P/N 1135
- 3/4" Belt
P/N 1137

