

# INSTRUCTION SHEET

**Denso Racing Alt Bracket Kit**  
**SBC 801, 8-801, 8-8018**

We want to help! If you have any comments or difficulty with this product, please contact technical support at



1833 DOWNS DRIVE, WEST CHICAGO, IL 60185  
 Tech / Sales Phone : (630) 957-4019  
 e-mail: tech@powermasterperformance.com

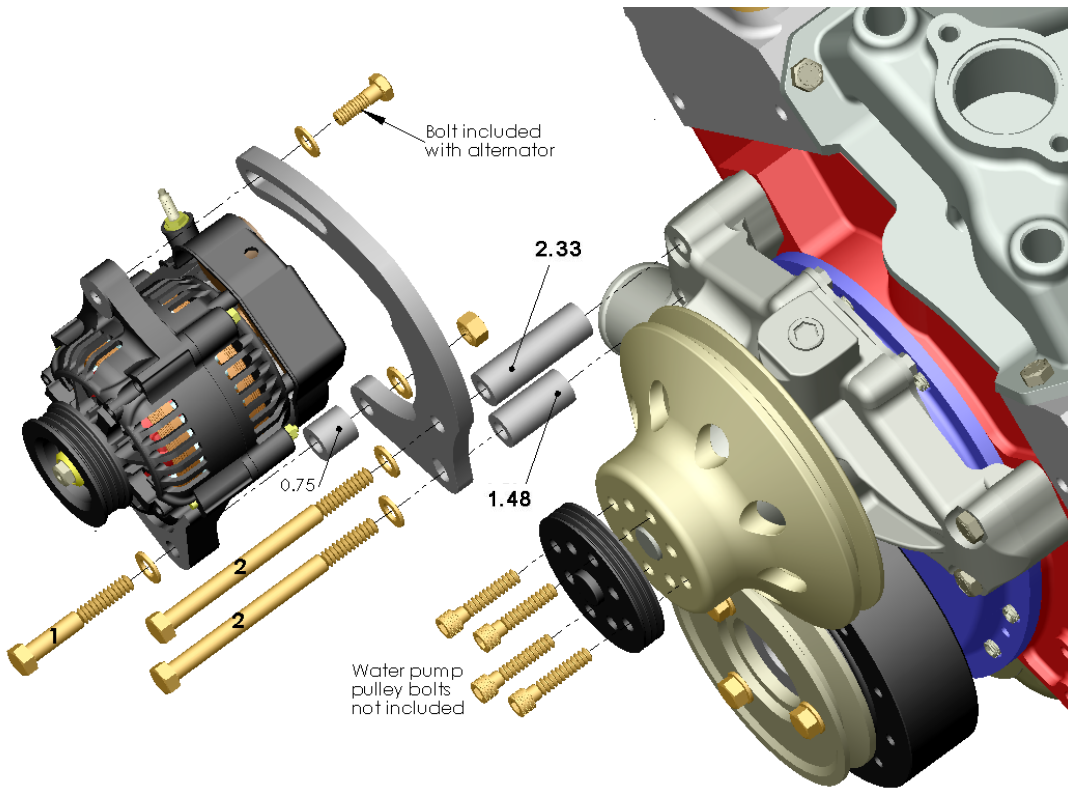
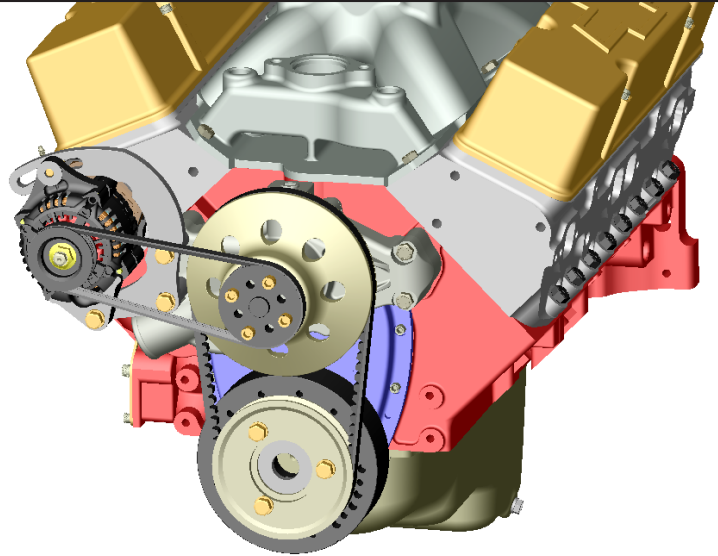

Assembly per illustration.

See reverse side for special notes and instructions

Diagram Ref. #	Part Description	P/N 801 Qty.	P/N 8-801 Qty.	P/N 8-8018 Qty.
	801 slotted bracket	1	1	1
1	3/8"-16 X 2 1/2" bolt	1	1	1
2	3/8"-16 X 4 1/2" bolt	2	2	2
	3/8" flat washer	4	4	4
	3/8"-16 nut	1	1	1
	25/64" ID X 3/4" OD X 2.33" spacer	1	1	1
	25/64" ID X 3/4" OD X 1.48" spacer	1	1	1
	25/64" ID X 3/4" OD X 0.75" spacer	1	1	1
	3G serp Water Pump Pulley		1	1
	3G serp Alternator Pulley		1	1
	24" 3G serp Belt (Gates 4030240)		1	1
	8162 one wire racing alternator		1	
	8168 XSvolt one wire racing alternator			1

## *Special Notes:*

- \* This system is for use with short water pumps only.
- \* This bracket can be assembled and mounted on either side of the water pump.
- \* **One wire** alternators require only the charge wire connection to function. An adequate charge wire should be run between the alternator and the positive battery post or the positive battery side of the safety cut off switch. If the alternator's charge wire is connected to the starter's battery connection or on any other positive point on the car that is on the switched side of the cutoff, the car may continue to run after the cutoff switch is opened.
- \* Be certain that any paint or corrosion is removed from the points where the bracket attaches to the engine block. Also be certain that an adequate ground path is supplied from the engine block to the negative battery post.
- \* Tension the belt to have ½" of deflection.
- \* If you are installing an 8-8018 Pro Series kit refer to the **XSvolt** alternator instruction sheets for special instructions.

